

## TECHNIQUES TO OPTIMIZE USAGE OF SATELLITE RF POWER

**Dr. X.T. Vuong, VP and Chief Scientist**

Artel, LLC, Herndon, Virginia, xvuong@artellic.com

### ABSTRACT

Power is a primary resource for a communication satellite. With conventional satellite payload design, one often encounters problems of under-utilization of RF power available on one channel (or one transponder or one downlink beam) that would waste available RF power and over-utilization requirement of RF power available on another, resulting in denial of services. The under-utilization and over-utilization problems can be avoided with any of the two technologies/techniques called ATPA (Active Transmit Phased Array) and MARS (Matrix Amplifier and Routing System). With ATPA or MARS, the available satellite RF power is automatically pooled and shared together.

Other than power sharing, ATPA allows the beams to be shaped/steered via their Beam Forming Networks (BFNs). ATPA also allows use of many low-power HPAs (e.g., SSPAs), vice a few high-power HPAs (e.g., TWTAs), to improve reliability. Iridium (S-Band, 1997) and Spaceway (Ka-Band, 2007) are two examples of satellites that implemented ATPA.

Matrix amplifier has many other names such as matrix transponder, multi-port amplifier. It initially lent itself to the scanned radar technology by using the Butler matrix to automatically pool and share power among HPAs. It was later enhanced to also include its capability of routing signals to different downlink beams without placing any switches or multiplexers after the HPA outputs and the term MARS was created to reflect its capability enhancement. Inmarsat-3 (L-Band, 1995) and AMSC/TMI's MSAT-1/TMI-1 (L-Band, 1995), ETS-6 (S-Band, 1996) and E172B (Ku-Band, 2017) are examples of satellites that implemented or will implement MARS.

This paper will describe the two techniques together with their principle parameters and characteristics. For ATPA, the characteristics include Intermod Beams and regrowth of shaped beams due to amplifier nonlinearity. For MARS, the characteristics include the routing vectors and creation of inter-port intermodulation products.

### I. INTRODUCTION

RF bandwidth and power are the two primary resources of a communication satellite. The former is limited by the bandwidth allocated by the ITU according to the ITU services that the satellite intends to provide, e.g., Ku-band FSS. The allocated bandwidth can be reused through spatial diversity of its satellite beams and polarization discrimination. The latter is limited by the amount power that can be provided by the satellite bus via its solar arrays.

With conventional satellite payload design, one often encounters problems of under-utilization of RF power available on one channel (or one transponder or one downlink beam) that would waste available RF power and over-utilization requirement of RF power available on another, resulting in denial of services. The under-utilization and over-utilization problems can be avoided with any of the two techniques called Active Transmit Phased Array (ATPA) and Matrix Amplifier and Routing System (MARS). With ATPA or MARS, the available RF satellite power is automatically pooled together and automatically shared.

This paper will describe the two techniques together with their principle parameters and characteristics.

## II. ATPA

### **II.1 ATPA Description**

ATPA is a blend of transponder and antenna technologies/techniques that has become feasible for satellite development because of advances in monolithic microwave integrated circuits (MMIC) amplifiers, attenuators, and phase shifters<sup>1, 2, 3, 4</sup>. The weight, volume, and uniformity in performance of their components are critical to the design and implementation of ATPAs. With MMIC, a large number of components can be replicated to provide more or less the same characteristics with minimal tuning. MMIC also provides high levels of integration that minimizes parasitic effects from bonding and wiring and results in the reduction of weight and volume. These characteristics make the design of ATPAs possible.

ATPA, as depicted in Exhibit II.1, consists of the following components:

- M beam input ports,
- One beam forming matrix (BFM),
- K solid state power amplifiers (SSPAs),
- K output circuits, and
- K radiating elements.

Signals entering from each beam input port will be split into K components with appropriate phases and powers by the BFM. The phase and powers of these components are also modified as they pass through the SSPAs, the output circuits, and the radiating elements. Since these components are coherent, they will be combined together in space at the far field of the radiating elements (i.e., on Earth). The combination is constructive at the desired main beam directions and destructive at the null directions.

BFM, as depicted in Exhibit II.2, combines the output ports of M beam forming networks (BFNs) with M-to-1 combiners. Each BFN consists of a 1-to-K splitter, and K pairs of attenuators/amplifiers and phase shifters. The values of the pairs are called the beam-weights of a BFN. Depending on the design, these attenuators/amplifiers and phase shifters may be programmable to provide variable loss/gain values (beam-weight magnitudes) and phase shift values (beam-weight phases) to steer and reconfigure the shapes of the beams.

The output circuits are components placed between the SSPAs and the radiating elements. These circuits may include components such as cables, waveguides, filters, and directional couplers. For practical design, to maximize available RF power, the SSPAs are often placed right at the inputs of the radiating elements.

Because each SSPA is accessed by all carriers, the available RF power from the SSPAs are pooled together and shared among the carriers. In general, to simplify the design and operation, a beam is often shaped/steered through adjustment of just only the phases of the beam-weights of the BFNs (the beam-weight magnitudes are kept the same); then the available RF power is shared equally among the beams and the carriers.

Note that ATPA provides better reliability for the same level of redundancy as a conventional satellite payload. It is because it uses many low power SSPAs which are more liable than high power TWTAs (travelling wave tube amplifiers) and failure of a few of them will only somewhat degrade the performance of the transmit beam coverage areas. In contrast, with a conventional satellite payload, the failure of a high power HPA will result in a total loss of a beam or a transponder, unless substantial redundancy, e.g., 2-for-1 or 3-for-2 is employed.

Iridium (S-Band, 1997) and Spaceway (Ka-Band, 2007) are two examples of satellites that implemented ATPA.

### **II.2 ATPA Performance**

To access the performance of ATPAs requires the development of a new software tool as software tools to analyze the performance of conventional payloads cannot be used in general<sup>3, 5, 6</sup>. This is because unlike the performance analysis for conventional satellite payloads, amplifier nonlinearity affects and beam forming analyses cannot in general be decoupled and therefore cannot be analyzed separately. The ATPA performance analysis is more complex and time consuming as it requires blending of amplifier loading analyses for each SSPA and the

beam forming analyses for each carrier and generated inter-modulation product (IMP). This complexity is even more evident when multiple BFNs are used since each SSPA must support all carriers from all beams.

In order to evaluate the performance of an ATPA, a conventional transmit satellite payload is defined as a reference to compare against. Logically, the Equivalent Passive Transmit Phased Array (EPTPA), depicted in Exhibit II.3, is selected as the reference. EPTPA is an ATPA with its SSPAs removed and replaced by HPAs placed in front of the BFM, with one HPA for each beam input. The HPAs are assumed to be identical and have the same gain and normalized AM/AM and AM/PM transfer functions as the SSPAs (which are also assumed to be identical). Because an ATPA consists of many SSPAs and the nonlinear performances of these SSPAs are part of the ATPA performances, so another reference parameter is also needed to define for reference comparison: EIPBO (effective input backoff). EIPBO is the average of the IPBOs of the SSPAs; when the beam-weight magnitudes are set to be equal, the SSPAs are all operated at the same input backoff which is EIPBO. Nevertheless, when the beam-weights are set to be unequal some SSPAs operate above and some below EIPBO.

ATPA performances are provided here for three cases. They are based on a study conducted for DISA/CFSE<sup>3</sup>; more and detailed results can be found in references<sup>3,5,6</sup>.

### II.2.1 Case 1: Single Beam, Equal Beam-Weight Magnitudes

Case 1 involves a single beam (i.e., a single BFN) with its beam-weight magnitudes being set equal. It can be proved mathematically and through computer simulation that the performances of the ATPA are identical to those of its EPTPA. That is:

$$G_{ATPA} = G_{EPTPA} = G_{PTPA} + G_{HPA}$$

$$(C/IM)_{ATPA} = (C/IM)_{HPA}$$

$G_{ATPA}$ ,  $G_{EPTPA}$ ,  $G_{PTPA}$ , and  $G_{HPA}$  are the gains experienced by a carrier as it passes through the ATPA, EPTPA, PTPA, and HPA respectively, and  $(C/IM)_{ATPA}$  and  $(C/IM)_{HPA}$  are the intermodulation performances of the ATPA and the HPA respectively. That is for these special simple cases, the ATPA analysis can be decomposed to loading analysis of a single amplifier<sup>8,9</sup> and beam forming analysis of a passive transmit phased array<sup>3</sup>.

### II.2.2 Case 2: Single Beam, Unequal Beam-Weight Magnitudes

For this case the transmit beam is formed through adjustment of also the beam-weight magnitudes. The use of unequal beam-weight magnitudes is desirable to shape the beam and to introduce a beam taper that reduces sidelobe levels.

Exhibits II.4 and II.5 are gain patterns of the ATPA versus EIPBO for Case 2 with 10 equal-power carriers (and a specific set of 64 radiating elements with a specific set of beam-weights and radiating elements). From the patterns it is observed that the first sidelobes of the gain patterns (that were suppressed by beam tapering) regrow with decreasing EIPBO (increasing total input power). Even though this regrowth phenomenon is observed for a specific scenario of Case 2, it is also true for any other scenarios of Case 2, with different carriers, radiation elements and beam weights. This regrowth phenomenon is analogous to the well known spectral sidelobe regrowth of a filtered PSK carrier when it is passed through a nonlinearity (e.g., an HPA). Control of sidelobe levels is important for migrating potential interference to other beams within the system or to adjacent satellite and terrestrial systems; thus care must be exercised when an ATPA is deployed and used with unequal beam-weight magnitudes.

The spatial gain pattern of the ATPA is not the same as its EPTPA, but it approaches that of its EPTPA with increased EIPBO.

For the intermodulation performances, the C/IM pattern of the ATPA improves (i.e., has higher values) but does not approach that of its EPTPA with increased EIPBO. Exhibit II.6 shows the spatial patterns of the EIRP of a third order (2A-B) IMP for the ten-equal-power-carrier scenario.

Note that for Case 2, a high-power carrier (L) and a low-power carrier (S) do not experience the same gains and same phase shifts as they pass through the SSPAs. Accordingly, the characteristics of the beam-weights must be adjusted for the carriers and therefore the spatial gain patterns of the carriers will not be the same, as depicted in Exhibit II.7. Their corresponding (2A-B) IMPs also have different EIRP patterns and are shown Exhibit II.8.

### *II.2.3 Case 3: Two Beams, Equal Beam-Weight Magnitudes*

For this case the ATPA beam-weight phases are adjusted to form transmit beams in two directions (two transmit beams). Scenarios with each beam supporting equal-power carriers were considered. Through simulation, it was found that the gain of the ATPA is approximately equal to that of its EPTPA; the total C/IM for the ATPA is worse than that of its EPTPA for any direction within a main beam. Intuitively, these results are expected because each SSPA is accessed by all carriers, as opposed to the EPTPA in which each HPA is accessed by only the carriers within the beam supported by the particular HPA.

At the main beams of the ATPA and its EPTPA, the IM effects are differentiated by two factors: a) the number of carriers accessing each nonlinearity (4 for the ATPA and 2 for the EPTPA) and b) the number of 3<sup>rd</sup> order IM beams (the number of beam-weight sets for all 3<sup>rd</sup> order IMPs) generated (6 for the ATPA and 2 for the EPTPA). The latter improves the IM performance of the ATPA relative to that of the EPTPA because the total IMP power is spread among more beams. This spatial dispersal effect reduces the IM interference on the main beams of the ATPA. Nevertheless, it creates IM beams at other locations that may be a source of interference to adjacent satellite and terrestrial systems; thus care must be exercised when an ATPA is deployed and used to support multiple beams.

Exhibit II.9 depicts the locations of the six IM beams. Two of the IM beams coincide with the two carrier (main) beams and are called Principal IM beams. Two of the other IM beams are “collinear” with the carrier beams and the angular distances between these two IM beams and the carrier beams are the same as the angular distance between the two carrier beams. The arrangement of the spatial locations of these IM beams relative to those of the carrier beams is analogous to the arrangement of the frequency locations of the two 3<sup>rd</sup> order intermodulation products (2A-B) and (2B-A) relative to the frequency locations of the two carriers (A and B). Accordingly, these two IM beams are named as intermodulation-beam products or IBxIB beams. The spatial locations of the last two IB beams are found to be symmetrical to those of the IBxIB beams. The general arrangement of the IBxIB beams in relation to those of the carrier beams has been studied by Sandrin<sup>7</sup>.

## **III. MARS**

### ***III.1 MARS Description***

MARS is a satellite payload technology/technique that can be applied to communication satellites to increase capacity and flexibility. MARS allows automatic sharing of satellite RF power among channels (transponders or downlink beams). It also allows the routing of signals from each uplink beam or channel to one or more downlink beams without placing any switches or multiplexers after the HPA outputs, thus reducing satellite payload complexity and output circuit losses. MARS is suitable for the design of satellite systems that require multiple downlink beams to cover different geographical areas with traffic loads that are substantially different and time-varying, e.g., HTS (High Throughput Satellite) systems. The power sharing concept was first developed at COMSAT Laboratories<sup>14, 15</sup>. It was initially based on the scanned radar technology by using the Butler matrix<sup>16, 17</sup> as its Input Matrix and Output Matrix building blocks (see Exhibit III.1) and called the Butler Transponder. Later more research work was conducted on the power sharing technology and names other than Butler Transponder for the same concepts were also used: Matrix Amplifier, Mutiport Amplifier, Hybrid Amplifier, Matrix Transponder, Multiport Transponder, and Hybrid Transponder<sup>18</sup>. The power sharing concept was generalized and enhanced to include its routing capability, and accordingly the term MARS (Matrix Amplifier and Routing System) was introduced and

used<sup>10-13</sup>. The first satellites to implement MARS were Inmarsat-3 (launched in 1995), AMSC/TMI's MSAT-1/TMI-1 (1995), and SkyTerra-1 (2010) at L-Band and ETS-6 (1996) at S-Band. MARS has advanced to Ku-Band with Eutelsat's E172B to be launched in 2017 to serve its Ku-Band HTS payload<sup>19</sup>.

As shown in Exhibit III.1, a generic MxKxN MARS consists of the following components:

- M input ports (1, ..., m, ..., M),
- N input ports (1, ...,n, ..., N),
- K identical HPAs (1, ..., k, ..., K)  $K \geq N$ ,
- One KxM input matrix, and
- One NxK output matrix.

Each signal entering one of the M input ports is split into K components of supposedly equal power and appropriate phases set by the input matrix. Each of these components, after amplification by one of the K supposedly identical HPAs, is split further by the output matrix to N subcomponents of supposedly equal power and appropriate phases. Consequently at each MARS output port, there will be a total of KN equal power subcomponents. These components are coherent (i.e., originated from the same source) and therefore their voltages are combined together vectorially. The combination can be destructive (totally out-of-phase), constructively (totally in-phase) or somewhere in between (depending on the phases set by the input and output matrices), resulting in the routing to one or more of the output ports. For MARS to be able to automatically share the HPA power among the ports, the number of the output ports must not exceed the number of the HPAs (i.e.,  $N \leq K$ ).

Since the HPAs are assumed to be identical and each is loaded with the same number of signal components of the same magnitudes (but different phases), the K components of each signal, after passing through the HPAs, will experience the same voltage gain and the same phase shift. This implies that the HPAs do not have any effects on the routing of signals. They do, however, have nonlinear effects, e.g., intermodulation effects which degrade the BER-performance of signals, and will be briefly addressed in Section III.2.

Defining  $\mathbf{P}(K \times M)$  and  $\mathbf{Q}(N \times K)$  as the matrix transfer functions of the input and output matrices, and  $p_{km}$  and  $q_{nk}$  as their corresponding entries, then by definition,

$$\text{Mag}(p_{km}) = |p_{km}| = \text{constant} (= (1/K)^{1/2} \text{ for lossless input matrix}) \quad (1)$$

$$\text{Mag}(q_{nk}) = |q_{nk}| = \text{constant} (= (1/N)^{1/2} \text{ for lossless output matrix}) \quad (2)$$

Then the complete (input-to-output) matrix transfer function  $\mathbf{T}(N \times M)$  for MARS, excluding the nonlinearity effects of the HPAs, is:

$$\mathbf{T} = \mathbf{Q} \mathbf{P} \quad (3)$$

Defining  $\mathbf{T}$  and  $\mathbf{P}$  by their column vectors, i.e.,

$$\mathbf{T} = [\mathbf{t}_1 : \mathbf{t}_2 : \dots : \mathbf{t}_m : \dots : \mathbf{t}_M] \quad (4)$$

$$\mathbf{P} = [\mathbf{p}_1 : \mathbf{p}_2 : \dots : \mathbf{p}_m : \dots : \mathbf{p}_M] \quad (5)$$

Then

$$\mathbf{t}_m = \mathbf{Q} \mathbf{p}_m \quad (6)$$

where  $\mathbf{p}_m$  is the column #m of the matrix  $\mathbf{P}$  which represents the vector transfer function from MARS input port #m to the output ports of the input matrix; and  $\mathbf{t}_m$  is the column #m of the matrix  $\mathbf{T}$  which represents the vector transfer function MARS input port #m to the MARS output ports.

From Eq. (6) it is noted that the output matrix  $\mathbf{Q}$  affects the routing of all signals (i.e., signals entering any MARS input ports), but the column vector  $\mathbf{p}_m$  of the input matrix  $\mathbf{P}$  only affects the routing of signals entering MARS input port #m. Accordingly, if the required routing of signals change from time to time, it is desirable to fix the characteristics of the output matrix and only change the characteristics (more precisely the phases) of the columns of the input appropriately. The phase component of the column vector  $\mathbf{p}_m$  is termed the Routing Vector of MARS input port #m. The squares of the magnitudes of the column vector  $\mathbf{t}_m$  is termed the Power Distribution Vector associated with the Routing Vector.

$$\text{Routing Vector (of input port \#m)} = \text{Ang}(\mathbf{p}_m) = [\text{Ang}(p_{1m}) \text{ Ang}(p_{2m}) \dots \text{Ang}(p_{km}) \dots \text{Ang}(p_{Km})]^T \quad (7)$$

$$\text{Power Distribution Vector} = [|t_{1m}|^2 \ |t_{2m}|^2 \dots |t_{nm}|^2 \dots |t_{Nm}|^2]^T \quad (8)$$

Note that the dimension of the routing vector is K; however, the routing is based on the relative values of the phases, one phase value is redundant and can be fixed to any arbitrary value and the rest can be made programmable.

When MARS is used as a power-sharing-only system with fixed one-to-one routing between the input and output ports, the following relationships must hold true:

$$\mathbf{M} = \mathbf{N} \quad (9)$$

$$\mathbf{T} = \mathbf{Q} \mathbf{P} = c \mathbf{E} \quad (10)$$

Where  $c$  is a complex constant; and  $\mathbf{E}$  is a row interchanging transformation matrix which has one and only one "1" at each row (and column) and "0" for any other entries. The square matrix  $\mathbf{E}$  includes the symmetric identity matrix  $\mathbf{I}$  and the rotated identity matrix  $\mathbf{I}^R$ :

$$\mathbf{I}^R = \begin{bmatrix} \bigcirc & & & 1 \\ & 1 & & \\ & & \cdot & \\ 1 & & & \bigcirc \end{bmatrix}$$

### III.1.2 Power-Sharing-Only MARS - Realization

To construct a power-sharing-only MARS with one-to-one routing, the input and output matrices must satisfy the requirements described by Eqs. (1), (2), (9), and (10) and must be physically realizable by microwave components. When the number of HPAs  $K$  is an integral power of 2 (i.e.,  $K = 2^x$  for any positive integer  $x$ ), it can be shown that a power-sharing-only MARS can be constructed with general matrices  $\mathbf{G}(K \times K)$ 's<sup>10</sup>.  $\mathbf{G}(K \times K)$  is defined recursively by Exhibit II.2 where  $\mathbf{G}(2 \times 2)$  is a regular microwave hybrid (i.e., (1:1, 90°-lag) hybrid or coupler) and  $\mathbf{G}(2K \times 2K)$  can be constructed from two hybrid matrices  $\mathbf{G}(K \times K)$ 's and  $K$  regular hybrids  $\mathbf{G}(2 \times 2)$ 's with two connection rules as described in Exhibit III.2. Note that it can be shown<sup>10</sup> that there are totally  $N_1$  different  $\mathbf{G}(2K \times 2K)$ 's that can be constructed from  $\mathbf{G}(K \times K)$ 's and totally  $N_2$  different  $\mathbf{G}(2K \times 2K)$ 's that can be constructed from  $\mathbf{G}(2 \times 2)$ 's, where:

$$N_1 = 2^K K! \quad (11)$$

$$N_2 = (2^K K!) (2^{K-1} (K-1)!) \dots (2^2 2!) \quad (12)$$

Note that  $\mathbf{G}(2 \times 2)$  or (1:1, 90°-lag) hybrid is also called a (3-dB, 90°) hybrid and its matrix transfer function is

$$\mathbf{G}(2 \times 2) = \frac{1}{\sqrt{2}} \begin{bmatrix} 1 & e^{-j90} \\ e^{-j90} & 1 \end{bmatrix} = \frac{1}{\sqrt{2}} \begin{bmatrix} 1 & -j \\ -j & 1 \end{bmatrix}$$

Two families of the hybrid matrix  $\mathbf{G}$  are of interest: the hybrid  $\mathbf{H}$  family (shown in Exhibit III.3) and the symmetric hybrid matrix  $\mathbf{S}$  family (shown in Exhibit III.4). The hybrid matrix  $\mathbf{H}$  is the Butler matrix without its phase shifters (i.e., phase shifter values set zeros) and symmetric hybrid matrix  $\mathbf{S}$  is symmetric ( $\mathbf{S}^T = \mathbf{S}$ ). Note that the Butler matrix<sup>17</sup> is a special kind of BFN that is used with a linear array of radiating elements in radar application to form equally-spaced scanning beams; the Butler is formed with alternate columns of regular hybrids and phase shifters<sup>16</sup>.

It can be shown that the general hybrid matrix  $\mathbf{G}(K \times K)$  has the following properties<sup>10</sup>:

$$\mathbf{G}^T(K \times K) \mathbf{G}(K \times K) = (-j)^x \mathbf{I}^R(K \times K) \quad (13a)$$

$$\mathbf{G}(K \times K) \mathbf{G}^T(K \times K) = (-j)^x \mathbf{I}^R(K \times K) \quad (13b)$$

$$\mathbf{G}^{*T}(K \times K) \mathbf{G}^*(K \times K) = (-j)^x \mathbf{I}^R(K \times K) \quad (13c)$$

$$\mathbf{G}^*(K \times K) \mathbf{G}^{*T}(K \times K) = (-j)^x \mathbf{I}^R(K \times K) \quad (13d)$$

and

$$\mathbf{G}^{*T}(K \times K) \mathbf{G}(K \times K) = \mathbf{I}(K \times K) \quad (14a)$$

$$\mathbf{G}^T(K \times K) \mathbf{G}^*(K \times K) = \mathbf{I}(K \times K) \quad (14b)$$

$$\mathbf{G}^*(K \times K) \mathbf{G}^T(K \times K) = \mathbf{I}(K \times K) \quad (14c)$$

$$\mathbf{G}(K \times K) \mathbf{G}^{*T}(K \times K) = \mathbf{I}(K \times K) \quad (14d)$$

These fit the general requirements described by Eq. (10) for a power-sharing-only MARS. Note that  $K = 2^x$ ;  $(j)^2 = -1$ ;  $\mathbf{G}^T$  is the transpose of  $\mathbf{G}$  or physically a mirror image of  $\mathbf{G}$  (i.e., the input ports of  $\mathbf{G}$  become the output ports of  $\mathbf{G}^T$  and vice versa); and  $\mathbf{G}^*$  is the complex conjugate of  $\mathbf{G}$  (i.e., a  $\mathbf{G}$  whose phase component changes sign) or physically a  $\mathbf{G}$  whose (1:1, 90°-lag) hybrids are replaced by (1:1, 90°-lead) hybrids.

A power-sharing-only MARS can be formed based on any of Eqs. (13a) - (13d) and (14a) – (14b). For instance, if Eq. (13a) is used, then the first matrix of the LHS of the equation ( $\mathbf{G}^{*T}(K \times K)$ ) is the MARS input matrix and the last/second matrix ( $\mathbf{G}(K \times K)$ ) of the LHS of the equation is the MARS output matrix; and signals entering MARS input port #m will be routed to MARS output port #(K+1-m) for  $m = 1, 2, \dots, M$ . Similarly, if Eq. (14d) is used, then the first matrix of the LHS of the equation ( $\mathbf{G}(K \times K)$ ) is the MARS input matrix and the last/second matrix ( $\mathbf{G}^{*T}(K \times K)$ ) of the LHS of the equation is the MARS output matrix; and signals entering MARS input port #m will be routed to MARS output port m for  $m = 1, 2, \dots, M$ . Note that for a power-sharing-only MARS (with one-to-one routing), the number of input ports M must be equal to the number of output ports N and must not exceed the number of HPAs K. Note also that when M or N is less than K, some hybrids of the hybrid matrices may be unused and can be removed and unused ports are connected to match load.

### III.1.3 Flexible Routing MARS - Realization

The routing concept of the MARS technology/technique is inherent in the power sharing concept. To utilize MARS's routing capability, the output matrix should be realized by a general hybrid matrix  $\mathbf{G}(K \times K)$ , the input matrix can be realized like BFM with equal beam-weight magnitudes, i.e., by M 1:K dividers, M(K-1) phase shifters, and K M:1 combiners, as shown in Exhibit III.5. Routing results are addressed in the next section.

## III.2 MARS Performance

MARS performances with respect to routing capability, under effects of HPA nonlinearities, and under practical conditions where hybrids and HPAs are not ideal/identical were extensively studied and reported<sup>10</sup>. Some results are summarized here.

### III.2.1 Routing Capability

Exhibit III.6 summarizes routing results for (MxKxK) MARS for  $K = 2$  and 4 and with 2-bit phase shifters (i.e., with four different relative phase shift values  $0^\circ, -90^\circ, -180^\circ, \text{ and } -270^\circ$ ). The results show that with 2-bit phase shifters, signals from one input port can always be routed to any one output port, to any two output ports simultaneously with equal power split, and to all output ports simultaneously with equal power split (broadcast operation).

When the values of the phase shifters are not restricted, the number of ways that signals from one input port can be routed to the output ports increases significantly. For  $K = 2$ , signals from one input port can be routed to both output ports with any proportion of power split. For other values of K of the form  $K = 2^x$  where x is a positive integer, it is not possible (with the basic MARS design) to route signals from one input port to the output ports with any arbitrary proportion of the power split. For instance (for  $K = 2^x$  and  $K > 2$  with the basic MARS design), it is not possible to route signals from one input port to two output ports with unequal power split, and to three, five, six and seven of the output ports.

To enhance the routing capability, two (or more) input ports can be used to route the same signals to the output ports. With the enhancement, signals can now be routed to any two output ports with any proportion of power split, and to any three output ports, etc. The enhancement requires use of extra input ports, and more importantly some signals entering MARS are now coherent to each other. Signal coherence causes the HPAs to share the traffic load unevenly and that may require the HPAs to operate at a greater power backoff. Signal coherence was addressed in Reference<sup>10</sup> and is a topic that requires further study.

### III.2.2 MARS Nonlinearity

In contrast to conventional satellite payloads in which a single HPA is used to amplify only a limited number of signals (i.e., carriers); associated with a channel or a transponder; a MARS HPA is accessed by all signals appearing at every MARS input port, thus causing a larger number of intermodulation products (IMPs). Like the signals, these IMPs are coherent with those IMPs generated by the other MARS HPAs and their voltages are combined vectorially at the output ports. There are two types of IMPs: intra-port IMPs (IMPs created by signals of the same input port) and inter-port IMPs (IMPs created by signals of multiple input ports). Intra-port IMPs have the same relative phase characteristics as their corresponding signals and therefore they are combined in the same way as the corresponding signals. That is, they are routed to the same output ports as their corresponding signals. Inter-port IMPs, however, may or may not have the same relative phase characteristics as any of their corresponding signals and therefore may or may not be combined at the output ports in the same manner as the signals.

#### Inter-Port IMP Destinations

For a one-to-one routing MARS using a hybrid matrix **G** as its output matrix, there three interesting general results on destinations of inter-port third-order IMPs:

- The output port destination of a (2A-B) IMP is the output port destination of signal B.
- The output port destination of an (A+B-C) IMP is the output port destination of signal A, if signal B and signal C have the same output port destination.
- The output port destination of an (A+B-C) IMP is the output port destination of signal C, if signal A and signal B have the same output port destination.

Exhibit III.7 provides all results of destinations of (A+B-C) and (2A-B) IMPs as a function of destinations of signals A, B, and C for MARS with **G**(8x8) – which can be **H**(8x8) as shown in Exhibit III.3 or **S**(8x8) as shown in Exhibit III.4. To illustrate the use of the exhibit, the 1<sup>st</sup>, 15<sup>th</sup> and 36<sup>th</sup> elements of the 6<sup>th</sup> column of the exhibit [i.e., (6 1 1), (1 2 5) and (1 6)] are selected. Suppose there are two signals ( $f_1$  and  $f_2$ ) at output port #1, one signal ( $f_3$ ) at output port #2, three signals ( $f_4$ ,  $f_5$  and  $f_6$ ) at output port #5, and one signal ( $f_7$ ) at output port #7; then below are the IMPs associated with the port-types (6 1 1), (1 2 5) and (1 6) appearing at the output port #6:

$$\begin{aligned} (6 \ 1 \ 1): & \quad (f_7 + f_1 - f_2) \text{ and } (f_7 + f_2 - f_1) \\ (1 \ 2 \ 5): & \quad (f_1 + f_3 - f_4), (f_1 + f_3 - f_5), (f_1 + f_3 - f_6), (f_2 + f_3 - f_4), (f_2 + f_3 - f_5), \text{ and } (f_2 + f_3 - f_6) \\ (1 \ 6): & \quad (2f_1 - f_7) \text{ and } (2f_2 - f_7) \end{aligned}$$

#### Inter-Port IMP Power Levels and Phases

The power of an (A+B-C) IMP is independent from destinations of the signals A, B, and C. That is, an inter-port (A+B-C) IMP has the same power as an intra-port (A+B-C) IMP, as long as the corresponding signals A, B, and C of the inter-port IMP have the same power level as those of the intra-port IMP. Similar results are also true for a (2A-B) product.

The relative phase of an (A+B-C) IMP (i.e., the phase excluding those imbedded in the signals) are either the same or 180° different from each other, if the corresponding signals A, B, and C have the same power levels. Similar results are also true for a (2A-B) product.



IM Performance: MARS Versus Conventional Payload System

For comparison, the MARS has  $K$  input ports,  $K$  HPAs, and  $K$  output ports; the conventional (no-power sharing) payload system has  $K$  identical HPAs; and each input port of the two systems is loaded with equal number ( $Z$ ) of carriers (signals) which are equal in power and equally spaced in frequency. From analyses and simulated results, the following conclusions can be made:

- When frequency reuse is not employed at the input ports, MARS improves the IM performance over the conventional payload system.
- When the frequency band associated with each input port is fully reused, the IM performance of the MARS is worse than but approaches that of the conventional payload system as  $Z$  increases.

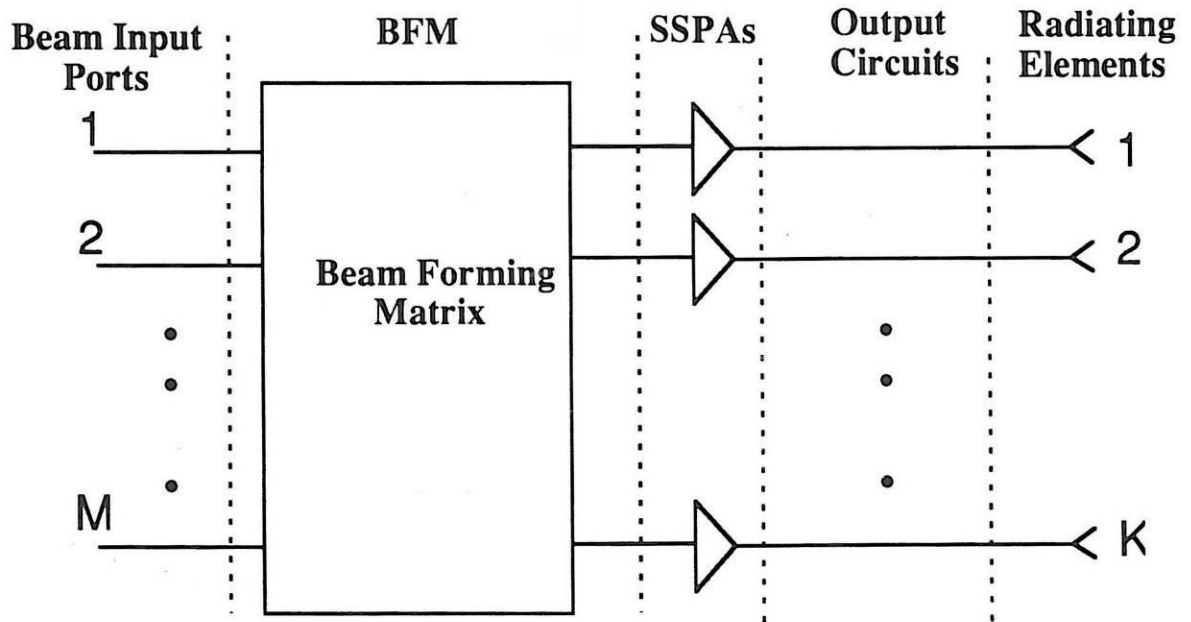

**Exhibit II.1:** General ATPA Block Diagram

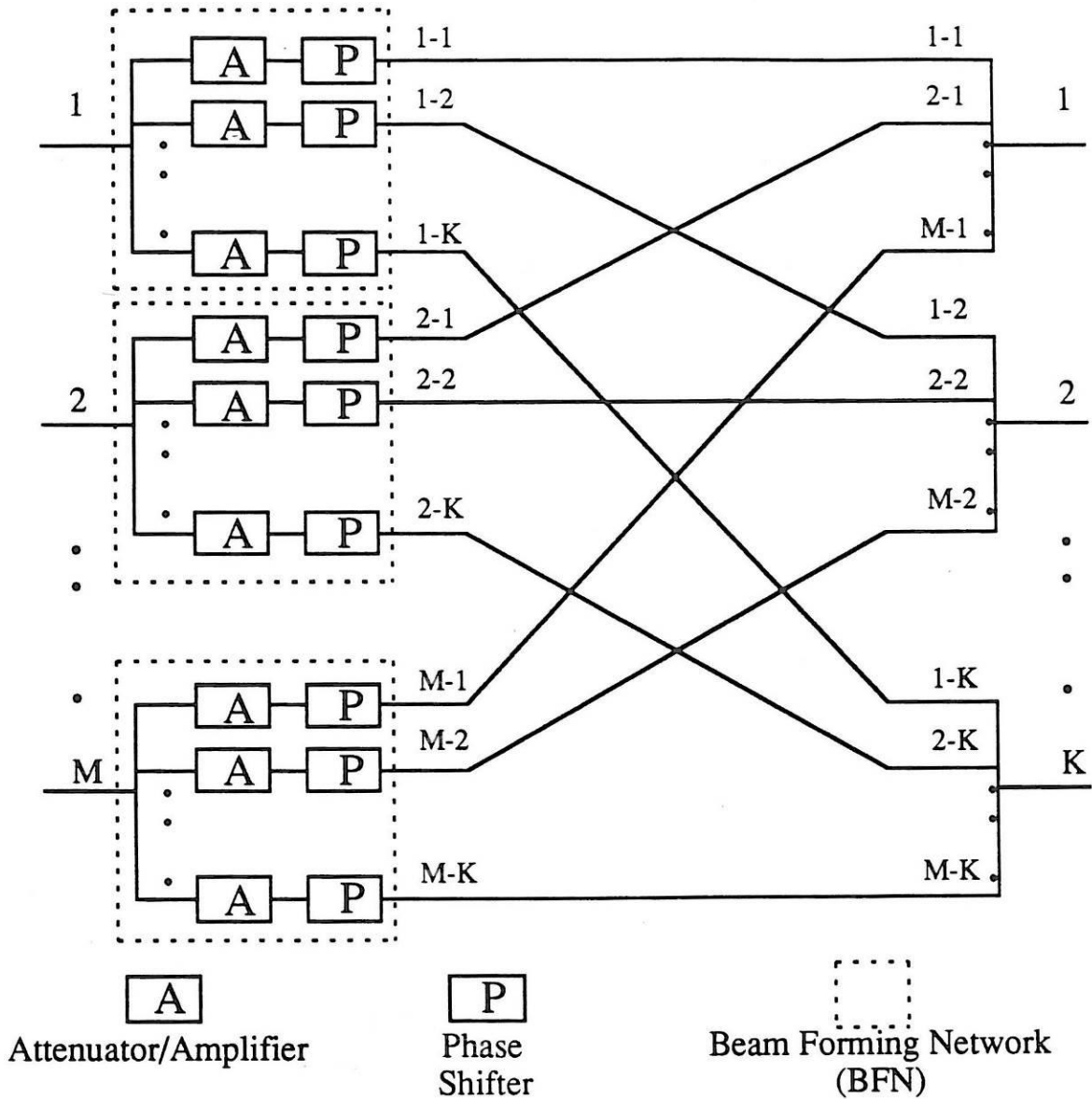

Exhibit II.2: General BFM Block Diagram

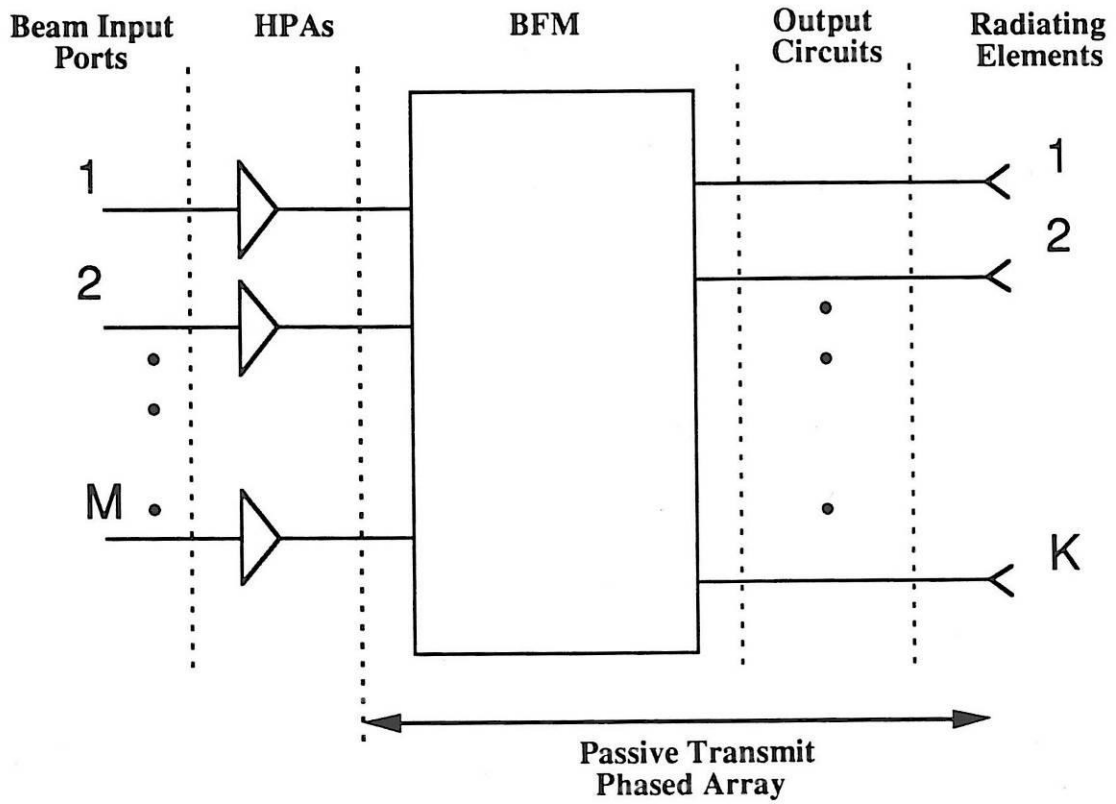
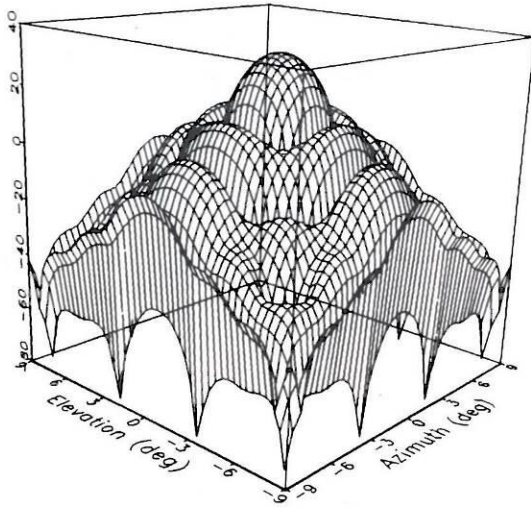
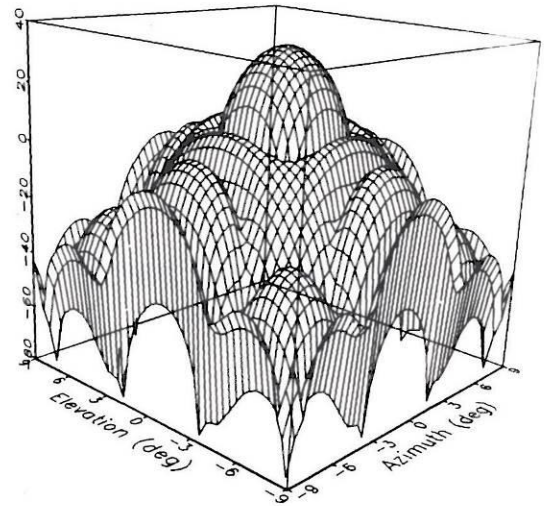

Exhibit II.3: General EPTPA Block Diagram



**a) 0 dB EIPBO**



**b) 6 dB EIPBO**

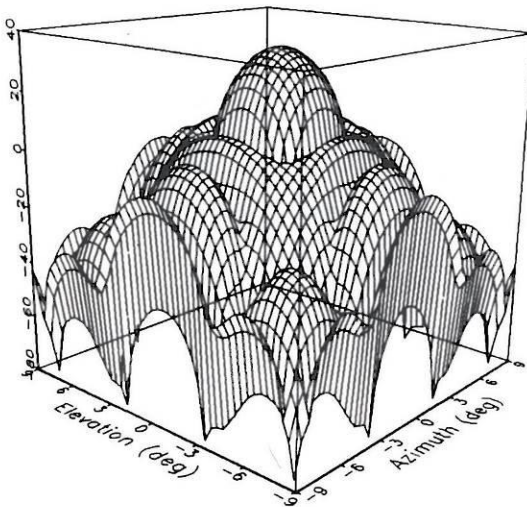

**c) 10 dB EIPBO**

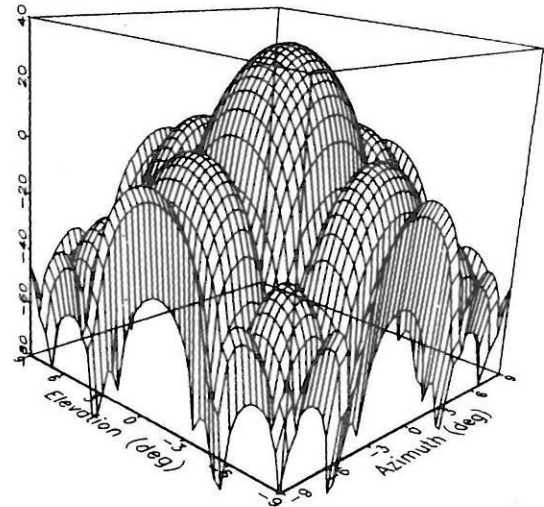

**d) 30 dB EIPBO**

**Exhibit II.4:** Spatial Gain Pattern of ATPA Versus EIPBO.

– Case 2 (Single Beam, Unequal Beam-Weight Magnitudes) with Ten Equal-Power Carriers.

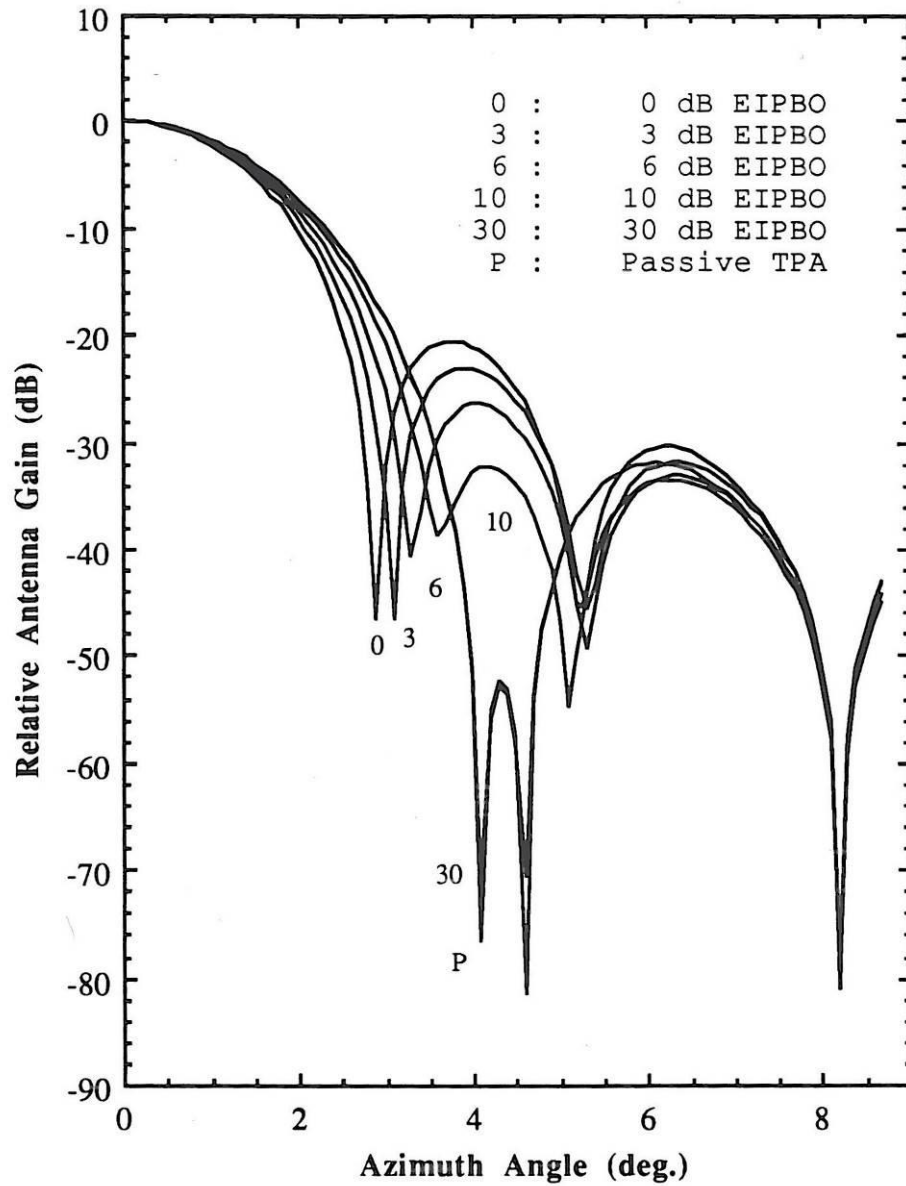

**Exhibit II.5:** Two-Dimensional Gain Pattern (Azimuth Cut) of ATPA Versus EIPBO.  
– Case 2 (Single Beam, Unequal Beam-Weight Magnitudes) with Ten Equal-Power Carriers.

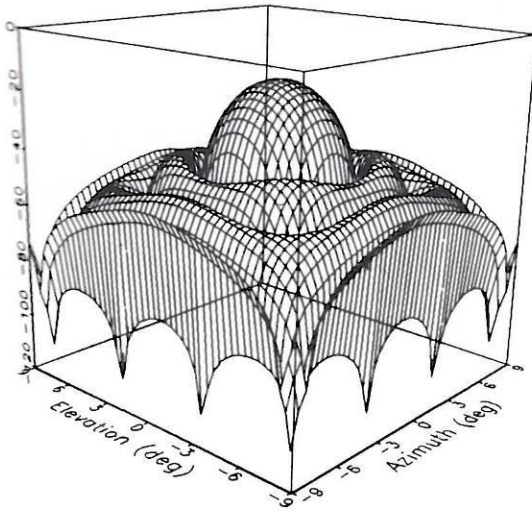

**a) 0 dB EIPBO**

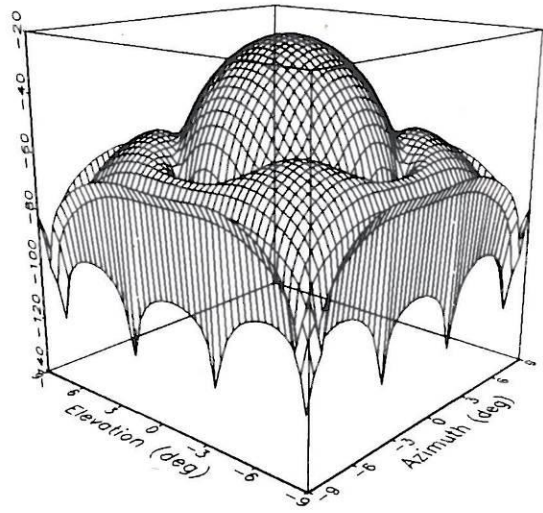

**b) 6 dB EIPBO**

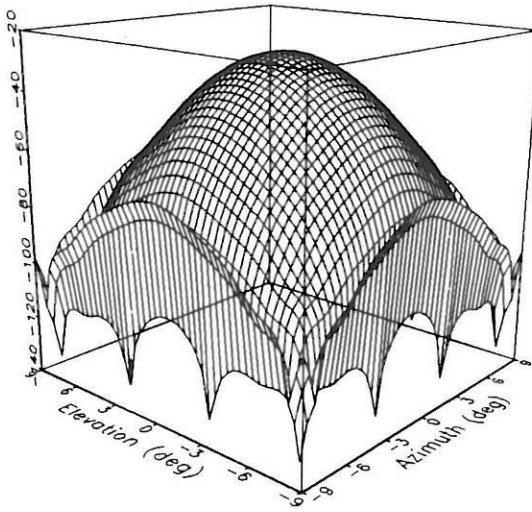

**c) 10 dB EIPBO**

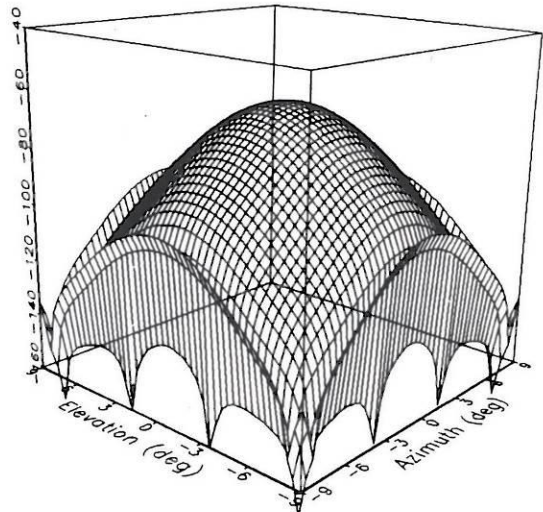

**d) 30 dB EIPBO**

**Exhibit II.6:** Spatial Pattern of (2A-B) IMP EIRP of ATPA Versus EIPBO.  
– Case 2 (Single Beam, Unequal Beam-Weight Magnitudes) with Ten Equal-Power Carriers.



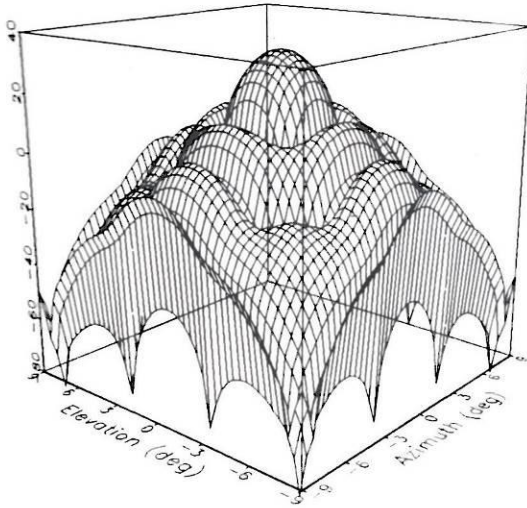

**a) Large Carrier Gain Pattern**

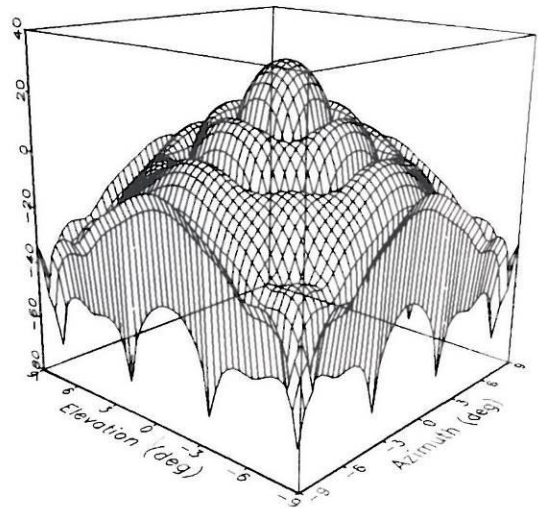

**b) Small Carrier Gain Pattern**

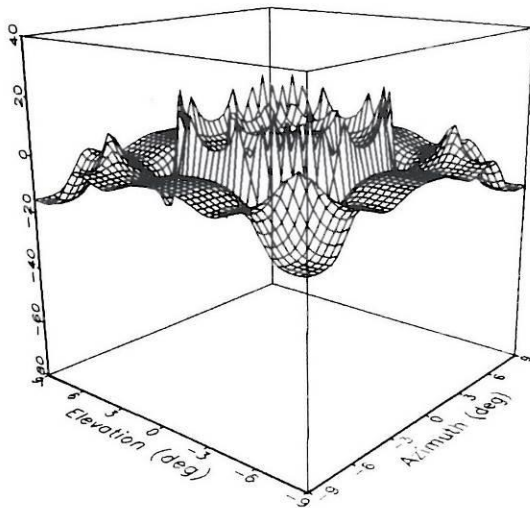

**c) Gain Pattern Difference**

At Beam Center,  
Difference is 2.37 dB  
(As Compared to 1.98 dB for EPTPA)

**Exhibit II.7:** Spatial Gain Patterns of Large Carrier and Small Carrier.

– Case 2 (Single Beam, Unequal Beam-Weight Magnitudes) with Two Unequal-Power Carriers.



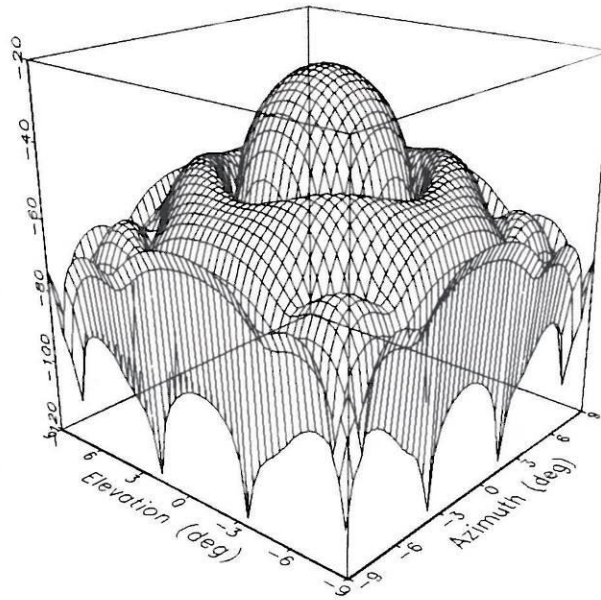

**a) EIRP of (2L-S)**

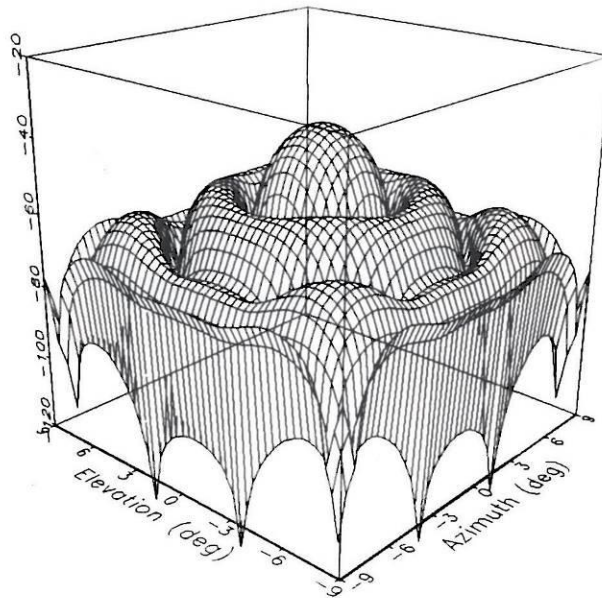

**b) EIRP of (2S-L)**

**Exhibit II.8:** Spatial Patterns of (2L-S) and (2S-L) IMP EIRPs.

– Case 2 (Single Beam, Unequal Beam-Weight Magnitudes) with Two Unequal-Power Carriers.

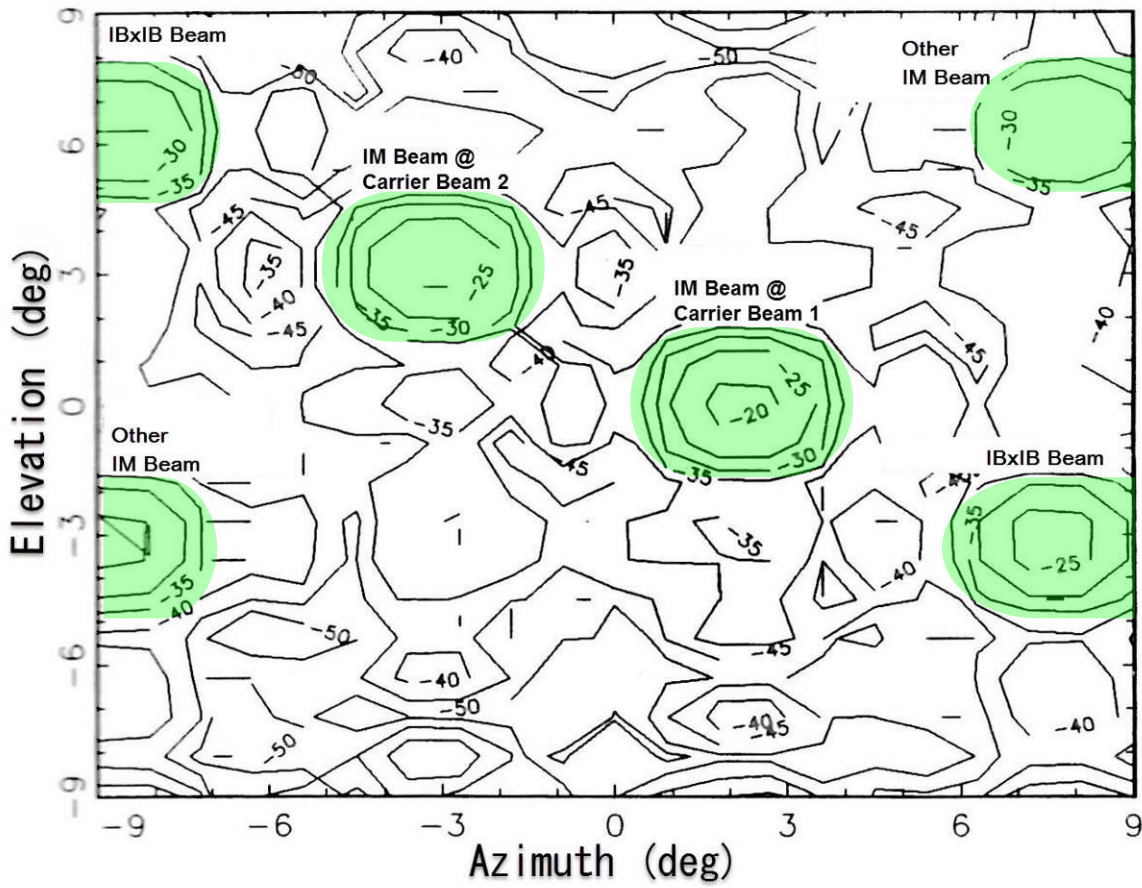

**Exhibit II.9:** Spatial Locations of the Six 3<sup>rd</sup> Order IM Beams.

– Case 3 (Two Beams, Equal Beam-Weight Magnitudes) with Two Equal-Power Carriers Per Beam.

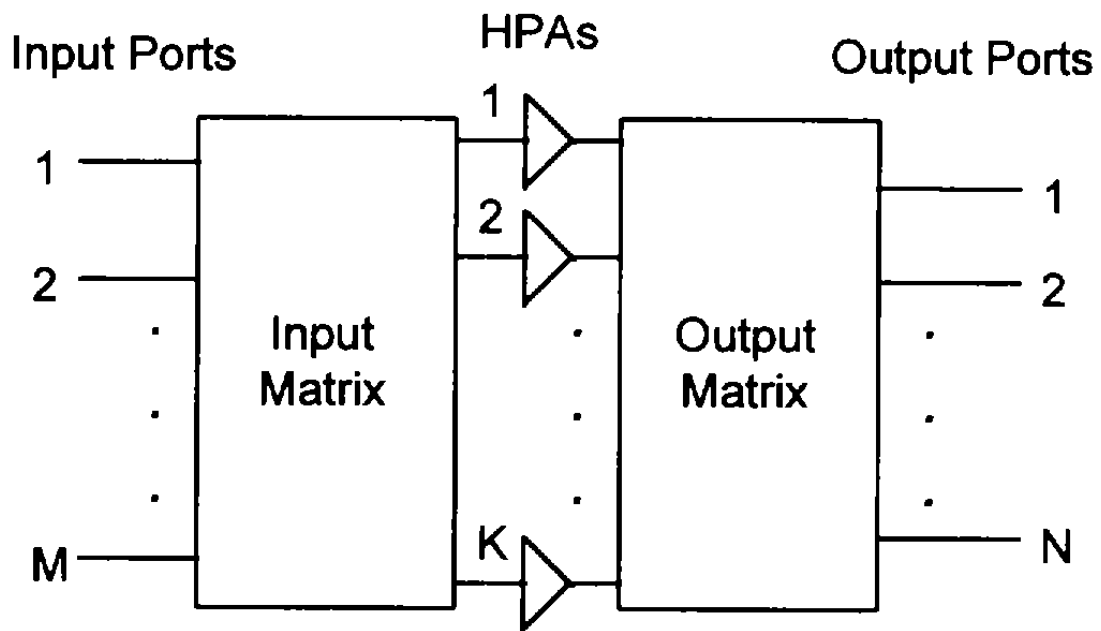
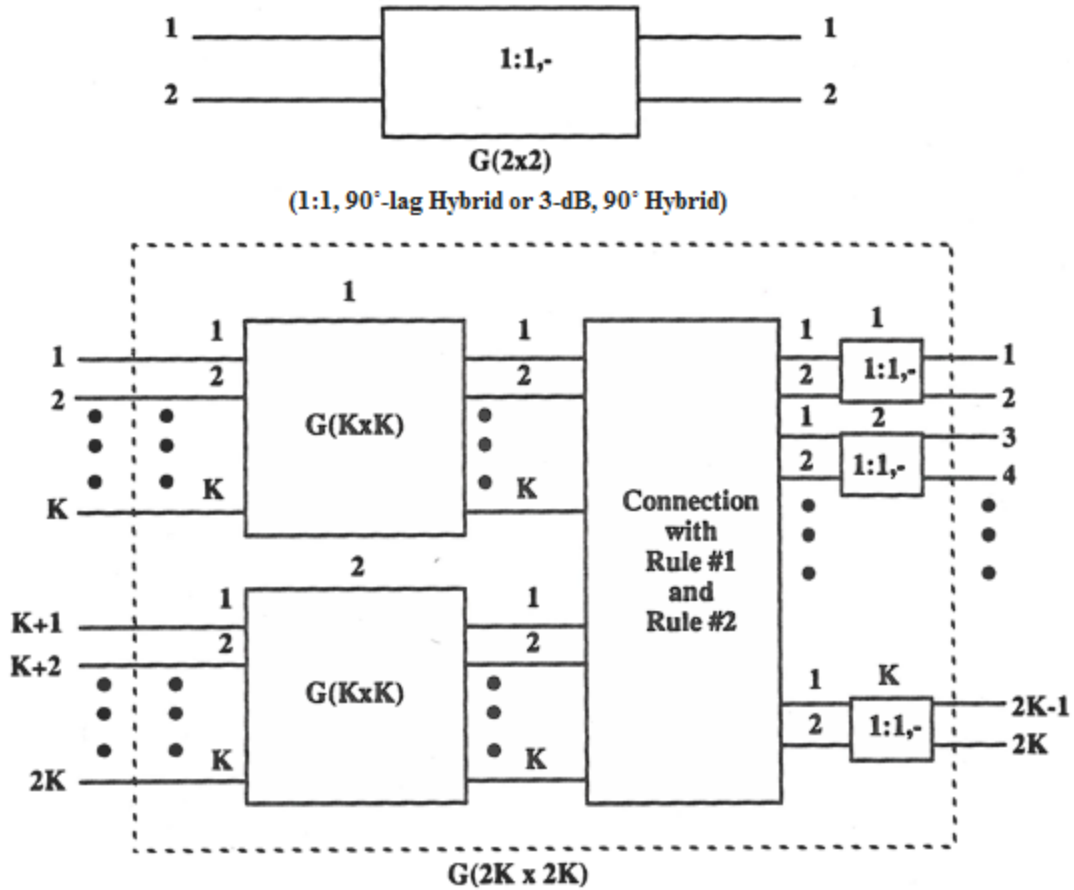

Exhibit III.1: General MxKxN MARS Block Diagram.



Rule #1: Each Output Port of a  $G(K \times K)$  Is Connected to One and Only One Hybrid  
 Rule #2: Output Port # $k$  of Each  $G(K \times K)$  Must Be Connected to the Same Hybrid

Exhibit III.2: Recursive Definition of General Hybrid Matrix  $G(K \times K)$ .

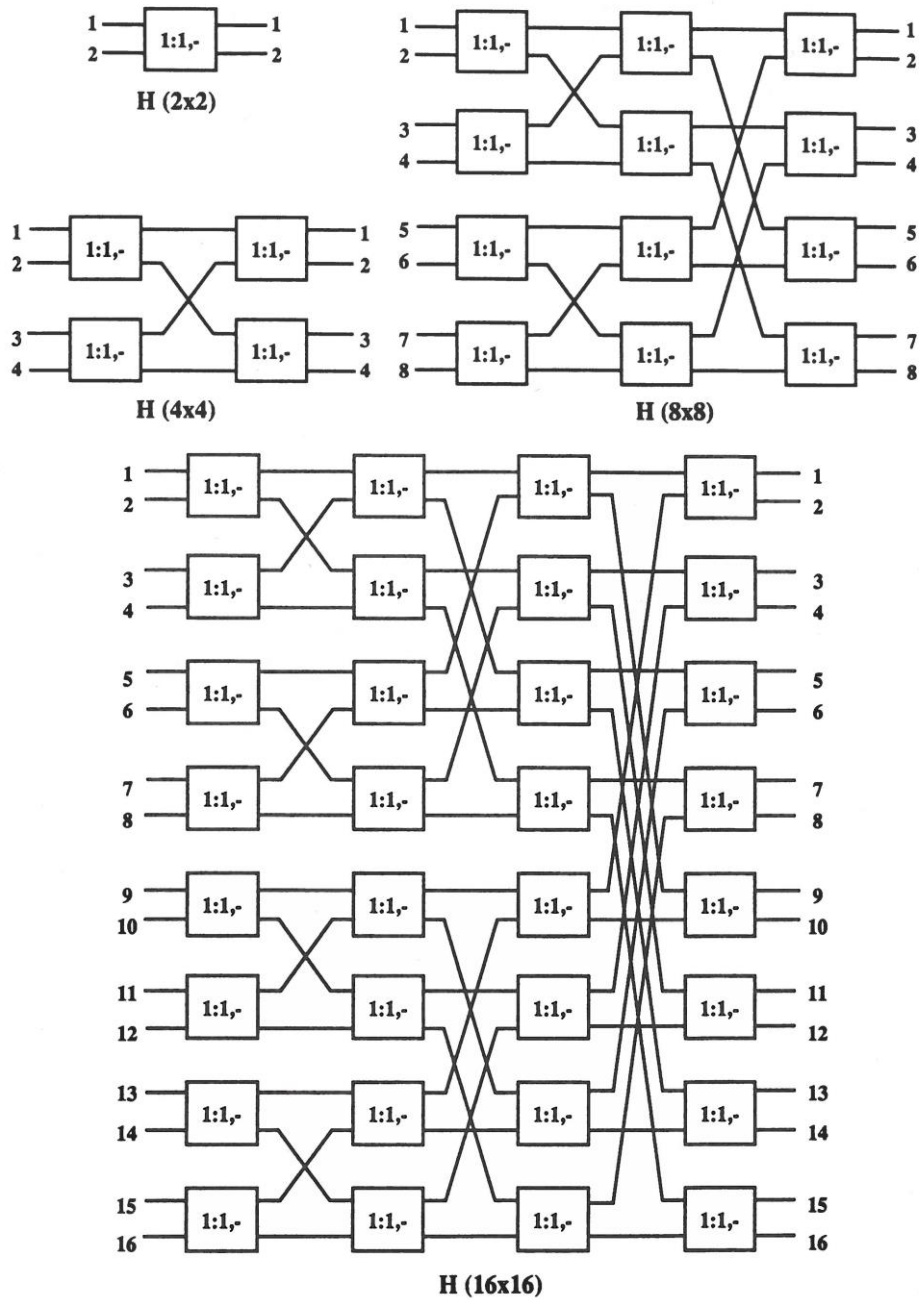
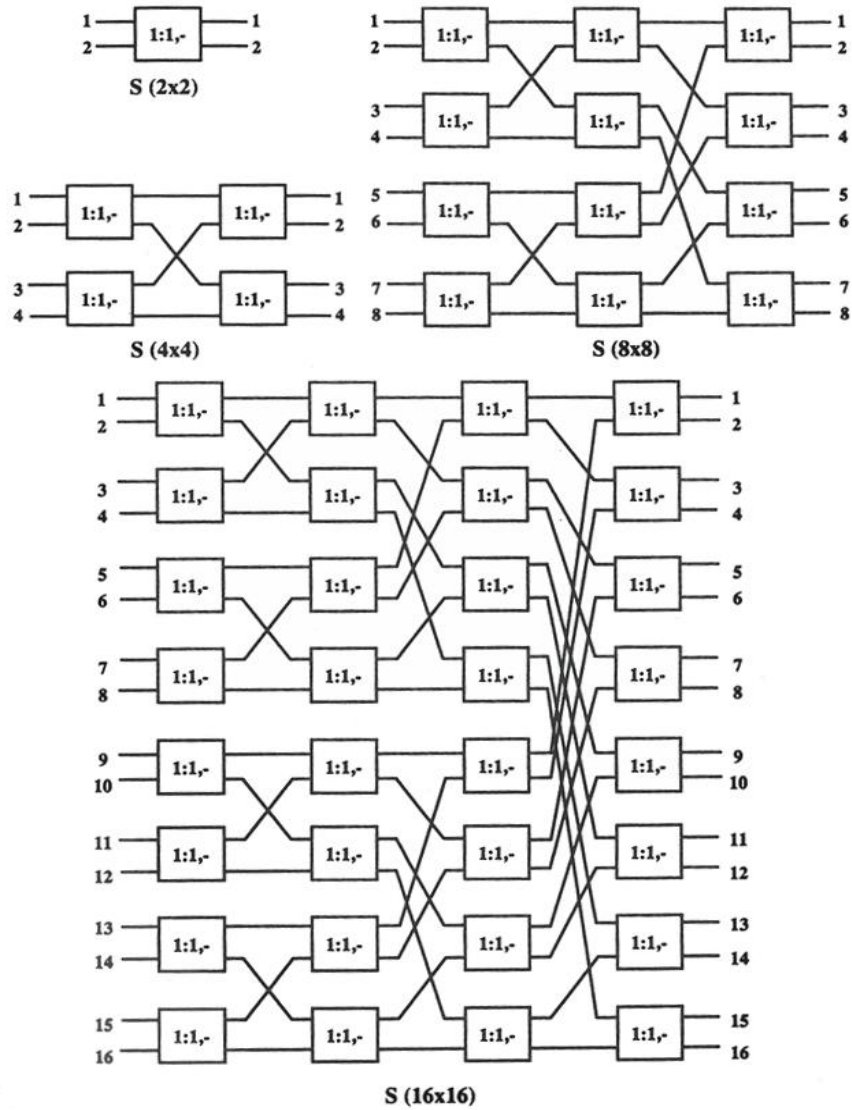

Exhibit III.3: Hybrid Matrix H(KxK) Family – K = 2, 4, 8, and 16.



**Exhibit III.4:** Hybrid Matrix  $S(K \times K)$  Family –  $K = 2, 4, 8, \text{ and } 16$ .

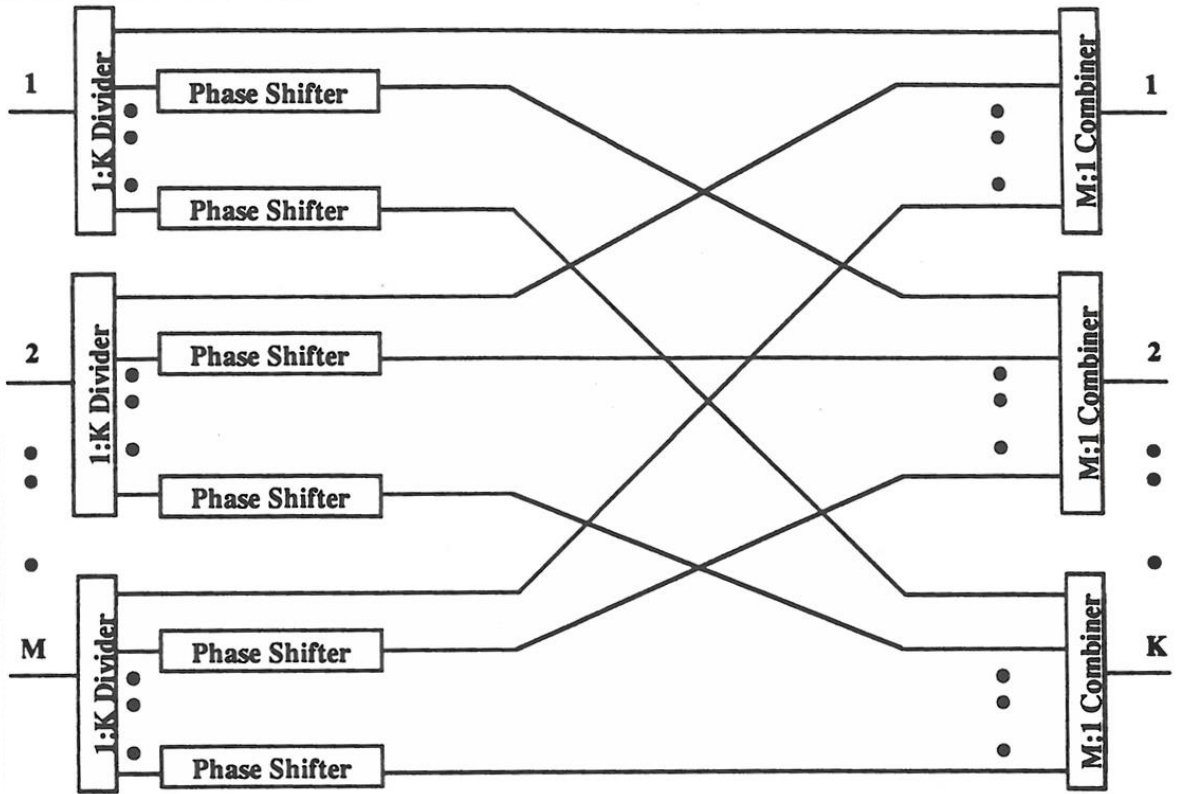

Exhibit III.5: Input Matrix of Flexible Routing MARS.

<b>K</b>	<b>Power Distribution Type</b>	<b>Power Distribution Vector</b>	<b>Routing Vector</b>
<b>2</b>	<b>1:0</b>	<b>1 0</b> <b>0 1</b>	<b>0 -270</b> <b>0 -90</b>
	<b>1:1</b>	<b>1 1</b>	<b>0 0</b>
<b>4</b>	<b>1:0:0:0</b>	<b>1 0 0 0</b>	<b>0 -270 -270 -180</b>
		<b>0 1 0 0</b>	<b>0 -270 -90 0</b>
		<b>0 0 1 0</b>	<b>0 -90 -270 0</b>
		<b>0 0 0 1</b>	<b>0 -90 -90 -180</b>
	<b>1:1:0:0</b>	<b>1 1 0 0</b>	<b>0 -270 0 -270</b>
		<b>1 0 1 0</b>	<b>0 0 -270 -270</b>
		<b>1 0 0 1</b>	<b>0 0 0 -180</b>
		<b>0 1 1 0</b>	<b>0 0 -180 0</b>
		<b>0 1 0 1</b>	<b>0 0 -90 -90</b>
		<b>0 0 1 1</b>	<b>0 -90 0 -90</b>
	<b>1:1:1:1</b>	<b>1 1 1 1</b>	<b>0 0 0 0</b>
	<b>5:1:1:1</b>	<b>5 1 1 1</b>	<b>0 -270 -270 -270</b>
		<b>1 5 1 1</b>	<b>0 0 -90 0</b>
<b>1 1 5 1</b>		<b>0 -90 0 0</b>	
<b>1 1 1 5</b>		<b>0 0 0 -90</b>	

**Exhibit III.6:** Routing Results for (MxKxK) MARS for K = 2 and 4 with 2-Bit Phase Shifters.



Output Ports Associated with Carriers A, B and C of Inter-Port Third-Order IMPs Appearing at																							
Output Port#1			Output Port#2			Output Port#3			Output Port#4			Output Port#5			Output Port#6			Output Port#7			Output Port#8		
A	B	C	A	B	C	A	B	C	A	B	C	A	B	C	A	B	C	A	B	C	A	B	C
1	2	2	2	1	1	3	1	1	4	1	1	5	1	1	6	1	1	7	1	1	8	1	1
1	3	3	2	3	3	3	2	2	4	2	2	5	2	2	6	2	2	7	2	2	8	2	2
1	4	4	2	4	4	3	4	4	4	3	3	5	3	3	6	3	3	7	3	3	8	3	3
1	5	5	2	5	5	3	5	5	4	5	5	5	4	4	6	4	4	7	4	4	8	4	4
1	6	6	2	6	6	3	6	6	4	6	6	5	6	6	6	5	5	7	5	5	8	5	5
1	7	7	2	7	7	3	7	7	4	7	7	5	7	7	6	7	7	7	6	6	8	6	6
1	8	8	2	8	8	3	8	8	4	8	8	5	8	8	6	8	8	7	8	8	8	7	7
2	2	1	1	1	2	1	1	3	1	1	4	1	1	5	1	1	6	1	1	7	1	1	8
3	3	1	3	3	2	2	2	3	2	2	4	2	2	5	2	2	6	2	2	7	2	2	8
4	4	1	4	4	2	4	4	3	3	3	4	3	3	5	3	3	6	3	3	7	3	3	8
5	5	1	5	5	2	5	5	3	5	5	4	4	4	5	4	4	6	4	4	7	4	4	8
6	6	1	6	6	2	6	6	3	6	6	4	6	6	5	5	5	6	5	5	7	5	5	8
7	7	1	7	7	2	7	7	3	7	7	4	7	7	5	7	7	6	6	6	7	6	6	8
8	8	1	8	8	2	8	8	3	8	8	4	8	8	5	8	8	6	8	8	7	7	7	8
2	3	4	1	3	4	1	2	4	1	2	3	1	2	6	1	2	5	1	2	8	1	2	7
2	4	3	1	4	3	1	4	2	1	3	2	1	3	7	1	3	8	1	3	5	1	3	6
2	5	6	1	5	6	1	5	7	1	5	8	1	4	8	1	4	7	1	4	6	1	4	5
2	6	5	1	6	5	1	6	8	1	6	7	1	6	2	1	5	2	1	5	3	1	5	4
2	7	8	1	7	8	1	7	5	1	7	6	1	7	3	1	7	4	1	6	4	1	6	3
2	8	7	1	8	7	1	8	6	1	8	5	1	8	4	1	8	3	1	8	2	1	7	2
3	4	2	3	4	1	2	4	1	2	3	1	2	3	8	2	3	7	2	3	6	2	3	5
3	5	7	3	5	8	2	5	8	2	5	7	2	4	7	2	4	8	2	4	5	2	4	6
3	6	8	3	6	7	2	6	7	2	6	8	2	6	1	2	5	1	2	5	4	2	5	3
3	7	5	3	7	6	2	7	6	2	7	5	2	7	4	2	7	3	2	6	3	2	6	4
3	8	6	3	8	5	2	8	5	2	8	6	2	8	3	2	8	4	2	8	1	2	7	1
4	5	8	4	5	7	4	5	6	3	5	6	3	4	6	3	4	5	3	4	8	3	4	7
4	6	7	4	6	8	4	6	5	3	6	5	3	6	4	3	5	4	3	5	1	3	5	2
4	7	6	4	7	5	4	7	8	3	7	8	3	7	1	3	7	2	3	6	2	3	6	1
4	8	5	4	8	6	4	8	7	3	8	7	3	8	2	3	8	1	3	8	4	3	7	4
5	6	2	5	6	1	5	6	4	5	6	3	4	6	3	4	5	3	4	5	2	4	5	1
5	7	3	5	7	4	5	7	1	5	7	2	4	7	2	4	7	1	4	6	1	4	6	2
5	8	4	5	8	3	5	8	2	5	8	1	4	8	1	4	8	2	4	8	3	4	7	3
6	7	4	6	7	3	6	7	2	6	7	1	6	7	8	5	7	8	5	6	8	5	6	7
6	8	3	6	8	4	6	8	1	6	8	2	6	8	7	5	8	7	5	8	6	5	7	6
7	8	2	7	8	1	7	8	4	7	8	3	7	8	6	7	8	5	6	8	5	6	7	5
2	1		1	2		1	3		1	4		1	5		1	6		1	7		1	8	
3	1		3	2		2	3		2	4		2	5		2	6		2	7		2	8	
4	1		4	2		4	3		3	4		3	5		3	6		3	7		3	8	
5	1		5	2		5	3		5	4		4	5		4	6		4	7		4	8	
6	1		6	2		6	3		6	4		6	5		5	6		5	7		5	8	
7	1		7	2		7	3		7	4		7	5		7	6		6	7		6	8	
8	1		8	2		8	3		8	4		8	5		8	6		8	7		7	8	

**Exhibit III.7:** Output Port Destinations of Inter-Port Third Order (A+B-C) and (2A-B) IMPs – One-to-One Routing MARS with Hybrid Matrix G(8x8) As Output Matrix.

## GLOSSARY

*	Complex conjugate operation.
(.)	Magnitude or amplitude of (.).
A	Amplifier or attenuator.
Ang(.)	Angle or Phase of (.)
ATPA	Active transmit phased array.
BER	Bit error rate.
BFM	Beam forming matrix.
BFN	Beam forming network.
c	Complex constant.
C	Carrier.
C/IM	Carrier to intermodulation.
dB	Decibel.
<b>E</b>	Row interchanging transformation matrix.
EIPBO	Equivalent input backoff.
EIRP	Effective isotropic radiated power.
EPTPA	Equivalent passive transmit phased array.
FSS	Fixed satellite services.
G	Gain.
G	General hybrid matrix G.
H	Hybrid matrix H.
HPA	High power amplifier.
HTS	High throughput satellite.
<b>I</b>	Symmetric identity matrix.
<b>I</b> <sup>R</sup>	Rotated identity matrix.
IB	Intermodulation beam.
IM	Intermodulation.
IMP	Intermodulation product.
ITU	International Telecommunication Union.
j	Complex symbol where $j^2 = -1$ .
K	Number of MARS's HPAs.
K	Number of ATPA's SSPAs or radiating elements.
LHS	Left hand side.
M	Number of MARS' input ports.
M	Number of ATPA's input ports.
Mag(.)	Magnitude or Amplitude of (.).
MARS	Matrix amplifier and routing system.
MMIC	Monolithic microwave integrated circuits.
N	Number of MARS' output ports.
NPR	Noise power ratio.
P	Phase shifter.
<b>P</b>	Matrix transfer function of MARS's input matrix.
PSK	Phased shift keying
PTPA	Passive transmit phased array.

<b>Q</b>	Matrix transfer function of MARS's output matrix.
RF	Radio frequency.
S	Symmetric hybrid matrix S.
SSPA	Solid state power amplifier.
T	Matrix transpose operation.
<b>T</b>	Matrix transfer function of MARS.
TPA	Transmit phased array.
TWTA	Travelling wave tube amplifier.

## REFERENCE

- <sup>1</sup>R.M. Sorbello, A.I. Zaghoul, R.K. Gupta, B.D. Geller, and F.T. Assal, "A Ku-Band Multibeam Active Phased Array for Satellite Communications," *Proceedings of the AIAA 14<sup>th</sup> International Communication Satellite Systems Conference*, Washington, D.C., March 1992.
- <sup>2</sup>D. Michel, B. Cogo, S. Bertrand, D. Roques, B.V. Saint-Andre, M. Belfort, and J.C. Zehen, "A Ku-Band Active Antenna Program," *Proceedings of the AIAA 14<sup>th</sup> International Communication Satellite Systems Conference*, Washington, D.C., March 1992.
- <sup>3</sup>X.T. Vuong, H. Paul, and S. Hryckiewicz, *Active Transmit Phased Array Analysis*, Final Report Prepared by SAIC for DISA/CFSE under Contract DCA 100-90-C-0058, December 1992.
- <sup>4</sup>*High Power Active Transmit Phased Array*, Final Report Prepared by COMSAT Laboratories for Air Force Materiel Command, Rome Laboratory, under Contract F30602-92-D-0133 (with SAIC Acted as Prime Contractor), August 1994.
- <sup>5</sup>X.T. Vuong, H. Paul, and S. Hryckiewicz, "Active Transmit Phased Array Analysis," *Classified Proceedings of the IEEE Military Communications Conference* (Unclassified Paper in Classified Sessions), Boston, October 1993.
- <sup>6</sup>X.T. Vuong, "Active Transmit Phased Array Analysis Program (ATPAL)," *Proceedings of the IEEE International Symposium on Phased Array Systems and Technology*, Boston, October 1996.
- <sup>7</sup>W.A. Sandrin, "Spatial Distribution of Intermodulation Products in Active Phased Array Antennas," *IEEE Transactions on Antenna and Propagation*, November 1973.
- <sup>8</sup>J.C. Fuenzalida, O. Shimbo, and W. Cook, "Time Domain Analysis of Intermodulation Effects Caused by Nonlinear Amplifiers," *COMSAT Technical Review*, Spring 1973.
- <sup>9</sup>D.S. Arnstein, X.T. Vuong, C.B. Cotner, and H.M. Daryanani, "The IM Microscope: A New Approach to Nonlinear Analysis of Signals in Satellite Communications Systems," *COMSAT Technical Review*, Spring 1992.
- <sup>10</sup>X.T. Vuong, H.I. Paul, and D. Cole, *Matrix Amplifier and Routing System (MARS)*, Final Report Prepared by SAIC for USAF/SMC under Contract No. F25606-91-D0005, August 1993.
- <sup>11</sup>X.T. Vuong, H.I. Paul, and D. Cole, "Matrix Amplifier and Routing System (MARS)," *Classified Proceedings of the IEEE Military Communications Conference* (Unclassified Paper in Classified Sessions), Boston, October 1993.
- <sup>12</sup>X.T. Vuong, H.I. Paul, and D. Cole, "Application of Matrix Amplifier and Routing System (MARS) Technology to Future DoD Satellite Payload Designs," *Classified Proceedings of the IEEE Military Communications Conference* (Unclassified Paper in Classified Sessions), Boston, October 1993.
- <sup>13</sup>X.T. Vuong, "Matrix Amplifier and Routing System (MARS) Analysis Program," *Proceedings of the IEEE Military Communications Conference*, Monterey, November 1997.
- <sup>14</sup>G.R. Welti, "Butler Matrix Transponder Improvements," US Patent Application, Serial No. 412399, November 1972.
- <sup>15</sup>W.A. Sandrin, "The Butler Matrix Transponder," *COMSAT Technical Review*, Fall 1974.
- <sup>16</sup>H.J. Moody, "The Systematic Design of the Butler Matrix," *IEEE Transactions on Antennas and Propagation*, November 1964.
- <sup>17</sup>J. Butler and R. Lowe, "Beamforming Matrix Simplifies Design of Electronically Scanned Antennas," *Electronic Design*, April 1961.
- <sup>18</sup>S. Egami and M. Kawai, "An Adaptive Multiple Beam System Concept," *IEEE Journal on Selected Areas in Communications*, May 1987.
- <sup>19</sup>Private Communication with Bernard Kasstan of Eutelsat, Paris, France, March, 2014.